

PRODUCT SPECIFICATION

paper towel- and soap-dispenser ONE brass ME-120

specification text

combination papertowel- and soap-dispenser, series PROOX ONE brass

dimensions: 400 x 318,5 x 120 mm

Paper towel and soap-dispenser combination, series PROOX One brass, PVD coated. Cover 1.5mm thickness. Perforated fill level indicator with 4mm drillings. Integrated soft-slide box for easy paper dispensing. Suitable for paper towels with a length of approx. 220-250mm and a folded width of approx. 95-120mm. High quality pump. Soap container with 1.2 litres capacity and lid. Filling quantity about 550 sheets of paper.

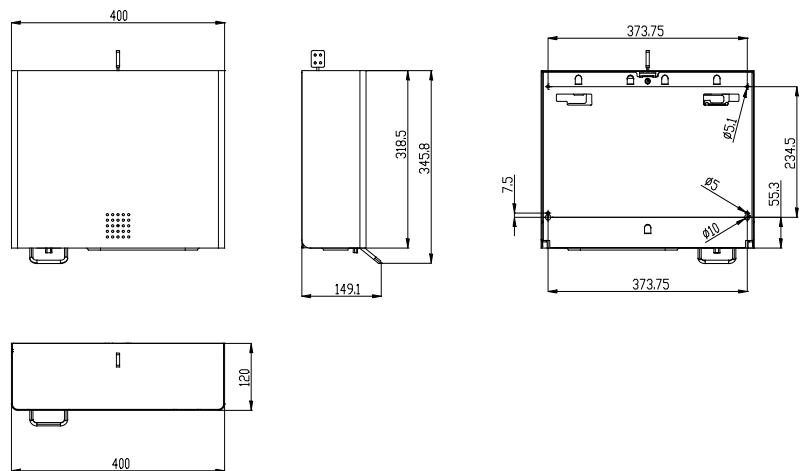

further product recommendations



spare roll holder
ME-390

single toilet roll holder
ME-380

toilet brush holder
ME-500

san. napkin disposal bin
ME-400

cloth hook
ME-560